

TCF 0804 H 650 04 A Engineering Specification

1. Scope

TCF 0804 H Series is a thin film common mode filter designed to suppress common mode noise for high speed differential data lines, such as USB 2.0, IEEE 1394, LVDS, DVI, **HDMI**, and **MIPI**.

These differential interfaces can be used in personal computers, note books, LCD monitors, LCD/PDP/DLP TVs, Blue-ray/DVD players, personal handheld equipments, etc.

2. Explanation of Part Number

TCF 0804 H 650 04 A
 (1) (2) (3) (4) (5) (6)

- (1) Product Type : TCF= Thin Film Common Mode Filter
- (2) EIA Dimension Code
- (3) Speed Identification Code: H= High Speed
- (4) Impedance(at 100MHz): 650= 65
- (5) Line Code: 04= 4 lines
- (6) Specialized Specification Code

3. Circuit Diagram & Dimension

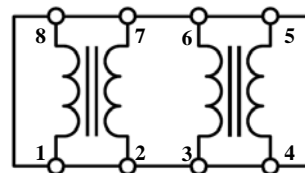
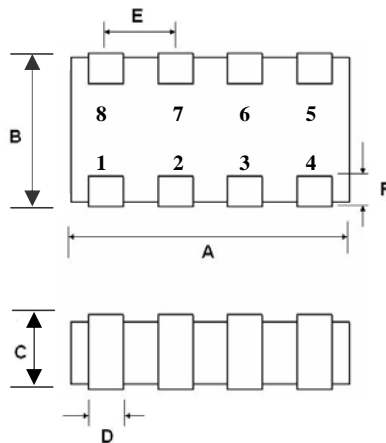

Unit: mm

Series	A	B	C	D	E	F
TCF 0804	2.0±0.2	1.05±0.2	0.6±0.15	0.25±0.15	0.5±0.1	0.2±0.15

4. Specifications

4.1. ABSOLUTE MAXIMUM RATINGS

PARAMETER	PARAMETER	RATING	UNITS
Rated Voltage	V_{DC}	5	V
Rated Current	I_{DC}	100	mA
Lead Soldering Temperature	T_{SOL}	260 (10 sec.)	$^{\circ}C$

4.2. ELECTRICAL CHARACTERISTICS

PARAMETER	MIN	TYP	MAX	UNITS
Common Mode Impedance (at 100 MHz)	52	65	78	
Cut-off Frequency		4		GHz
DC Resistance		3		
Insulation Resistance	10			

4.3. TYPICAL CHARACTERISTICS

Impedance vs Frequency Characteristics*

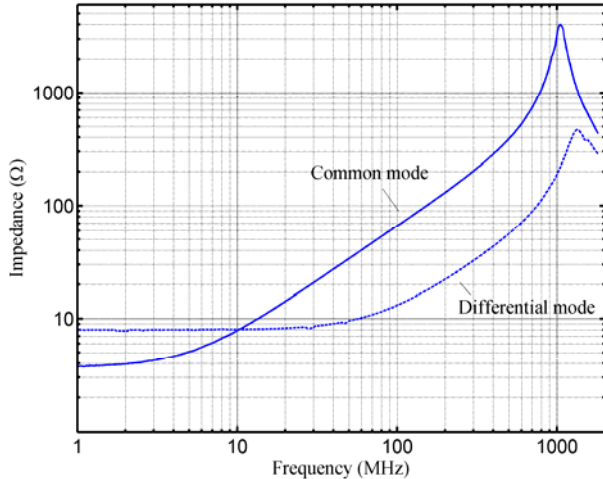

Insertion Loss vs Frequency Characteristics**

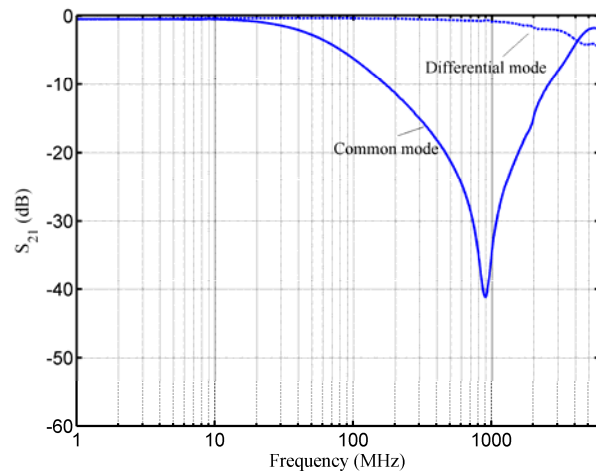

*Test Instrument: Agilent E4991A Impedance/Material Analyzer

**Test Instrument: Agilent E5071C ENA Series Network Analyzer

5. LAND LAYOUT

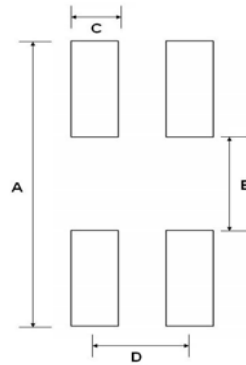

	mm
A	1.4
B	0.4
C	0.25
D	0.5

6. Recommendable reflow soldering

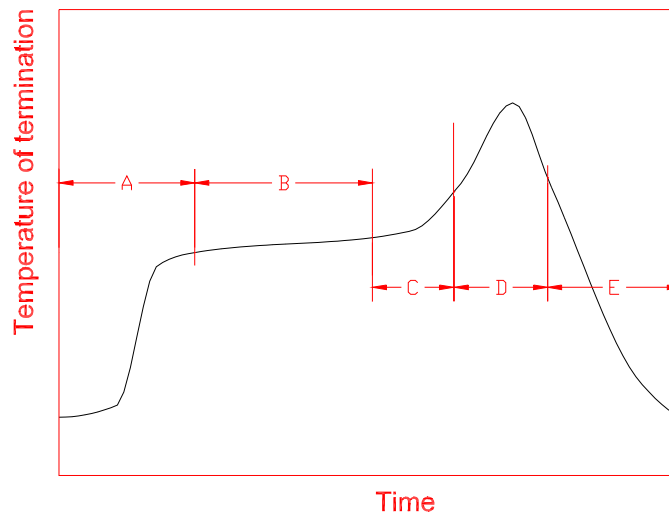

A	1 st rising temperature	The normal to Preheating temperature	30s to 60s
B	Preheating	140°C to 160°C	60s to 120s
C	2 nd rising temperature	Preheating to 200°C	20s to 40s
D	Main heating	if 220°C if 230°C if 240°C if 250°C if 260°C	50s~60s 40s~50s 30s~40s 20s~40s 20s~40s
E	Regular cooling	200°C to 100°C	1°C/s ~ 4°C/s

*According to J-STD-020C

7. Tape and reel specifications

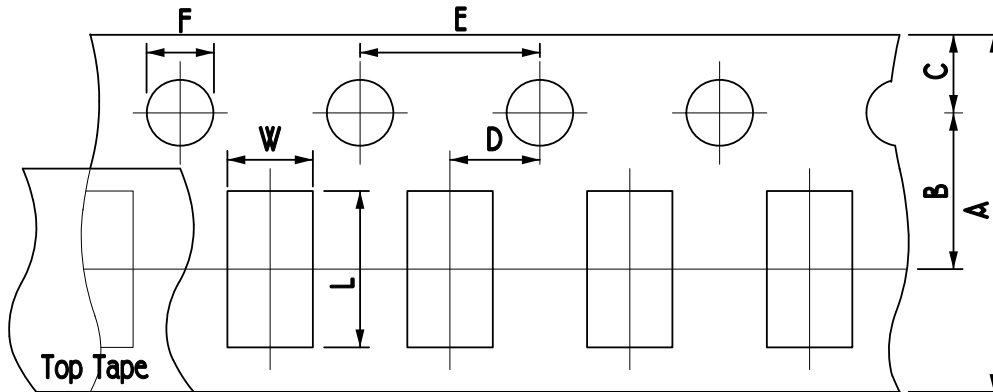

Type	A	B	C	D	E	F	L	W
0804	8.00±0.30	3.50±0.05	1.75±0.10	2.00±0.05	4.00±0.10	1.50±0.10	2.40±0.20	1.35±0.20

Unit: mm

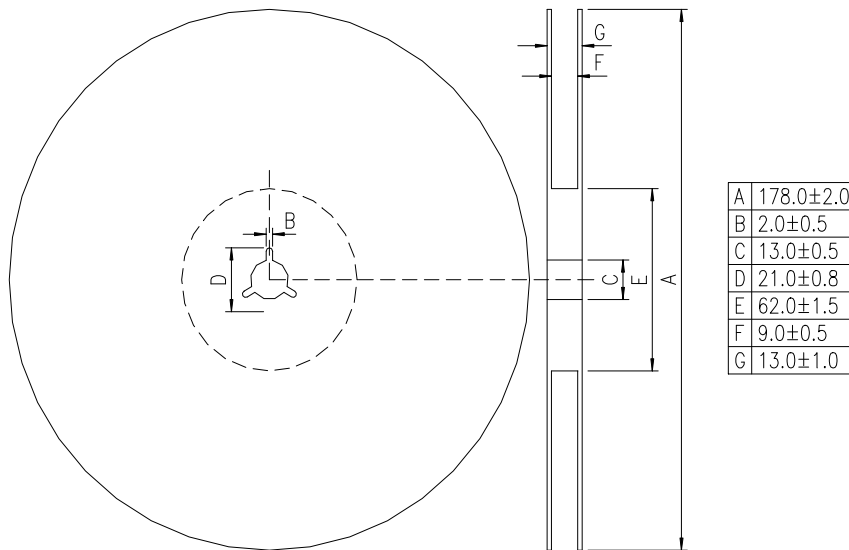

*Standard quantity : 5000pcs/Reel